



X3-ULTRA

15kW
|
30kW

Three-phase Hybrid Inverter

Commercial & Industrial
Hybrid Solution

Features

Three-phase Hybrid Inverter



Economic

- Maximum 200% oversize and 200% PV input power
- Maximum 36A input current per MPPT, support high power solar panel



Intelligent

- AI ready, forecasting solar generation and home consumption, smart energy management strategy
- VPP ready, SolaX cloud supports resource aggregator (2030.5, OpenADR)
- Support smart scene function, intelligent loads management (e.g., Heat pump, EV charger)
- Micro-grid ready, supporting a variety of scenarios, both on-grid and off-grid, balancing power between PCS and Hybrid in real time
- Support 7×24h scheduling mode
- Support Wireless meter solution
- Dual independent battery ports are ready to expand battery capacity free



Robust

- Robust back-up ability, switch over time <math>< 10\text{ms}</math>, up to 200% EPS output for 10s, support half-wave loads
- Stronger, EPS operation without battery



Safe

- IP66 protection level
- AC&DC SPD type II, always guarding the inverter
- AFCI optional



X3-ULTRA

15-30kW



X3-ULTRA (THREE PHASE)

X3-ULT-15KP X3-ULT-15K X3-ULT-19.9K X3-ULT-20K X3-ULT-25K X3-ULT-30K

INPUT PV	X3-ULT-15KP	X3-ULT-15K	X3-ULT-19.9K	X3-ULT-20K	X3-ULT-25K	X3-ULT-30K
Max.recommended PV array power [Wp]	30000	30000	40000	40000	50000	60000
Max.input DC power [W]	30000	30000	40000	40000	50000	60000
Max.DC voltage [V]	1000					
Nominal DC operating voltage [V]	600					
No. of MPP trackers / Strings per MPP tracker	3 (2 / 2 / 2)	2 (2 / 2)	2 (2 / 2)	2 (2 / 2)	3 (2 / 2 / 2)	3 (2 / 2 / 2)
Max. input current (input PV1 / input PV2 / input PV3) [A] ^①	PV1: 36 / PV2: 36 / PV3: 36	PV1: 36 / PV2: 36	PV1: 36 / PV2: 36	PV1: 36 / PV2: 36	PV1: 36 / PV2: 36 / PV3: 36	PV1: 36 / PV2: 36 / PV3: 36
Max. short circuit current (input PV1 / input PV2 / input PV3) [A]	PV1: 45 / PV2: 45 / PV3: 45	PV1: 45 / PV2: 45	PV1: 45 / PV2: 45	PV1: 45 / PV2: 45	PV1: 45 / PV2: 45 / PV3: 45	PV1: 45 / PV2: 45 / PV3: 45
MPPT voltage range [V]	160 - 950					
Start output voltage [V]	200					
OUTPUT AC(On-Grid)						
Nominal AC power [VA]	15000 (AS 4777 14999)	15000 (AS 4777 14999)	19999	20000	25000	30000 (AS 4777 29999)
Max. apparent AC power [VA]	16500 (AS 4777 14999)	16500 (AS 4777 14999)	19999	22000	27500	30000 (AS 4777 29999)
Rated grid voltage (AC voltage range) [V]	3P4W, 400 / 230					
Rated grid frequency [Hz]	50 / 60					
Nominal AC current [A]	21.8	21.8	29.0	29.0	36.3	43.5
Max. AC current [A]	24.0	24.0	29.0	31.9	39.9	43.5
Displacement power factor	1 (- 0.8 ~ 0.8)					
Total harmonic distortion (THDi, rated power) [%]	< 3					
INPUT AC						
Nominal AC power [VA]	15000	15000	19999	20000	25000	30000
Nominal AC current [A]	21.8	21.8	29.0	29.0	36.3	43.5
Rated grid voltage (AC voltage range) [V]	3P4W, 400 / 230					
Rated grid frequency [Hz]	50 / 60					
BATTERY						
Battery type	Lithium - ion					
Battery voltage range [V]	180 - 800					
Max. charge / Discharge current [A]	60 (30 × 2)					
EPS OUTPUT(WITH BATTERY)						
EPS peak power [VA]	2 time of rated power, 10s					
EPS rated power [VA]	15000	15000	19999	20000	25000	30000
EPS rated voltage [V], Frequency [Hz]	400 / 230; 50 / 60					
EPS rated current [A]	21.8	21.8	29.0	29.0	36.3	43.5
Switchover time [ms]	< 10					
Total harmonic distortion (THDv, linear Load) [%]	< 3					
POWER CONSUMPTION						
Internal consumption (night) [W]	< 5					
PROTECTION						
Anti-Islanding protection	Yes					
DC reverse polarity protection	Yes					
Insulation monitoring	Yes					
Residual current monitoring	Yes					
AC overcurrent protection	Yes					
AC short-circuit protection	Yes					
AC overvoltage protection	Yes					
Over-heat protection	Yes					
Battery reverse charging from grid	Yes					
Surge protection	Type II, DC and AC					
AFCI	OPT					

EFFICIENCY

Max. efficiency / European efficiency	98.0% / 97.7%
Rated battery charge / Discharge efficiency	98.5% / 97.0%

STANDARD

Safety	EN / IEC62109 - 1 / - 2
EMC	EN61000 - 6 - 1 / 2 / 3 / 4; EN61000 - 3 - 11 / 12; EN 5011; IEC 62920
Certification	VDE4105 / G99 / AS4777 / EN50549 / CEI 0 - 21 / IEC61727 / PEA / MEA / NRS - 097 - 2 - 1 / RD1699 / TOR

GENERAL DATA

Protection class	IP66
Operating temperature range [°C]	- 35 ~ 60 (Derating above + 45)
Relative humidity [%]	0 ~ 100
Altitude [m]	< 3000
Storage temperature [°C]	- 40 ~ +70
Demensions (WxHxD) [mm]	696 × 526 × 240
Weight [kg]	47
Cooling concept	Smart cooling
Topology	Transformerless
Communication	Modbus (RS485), Meter (RS485), DI × 5, DO × 2

①: Input PV3 only available for 15KP, 25K and 30K.

CIRCUIT DIAGRAM

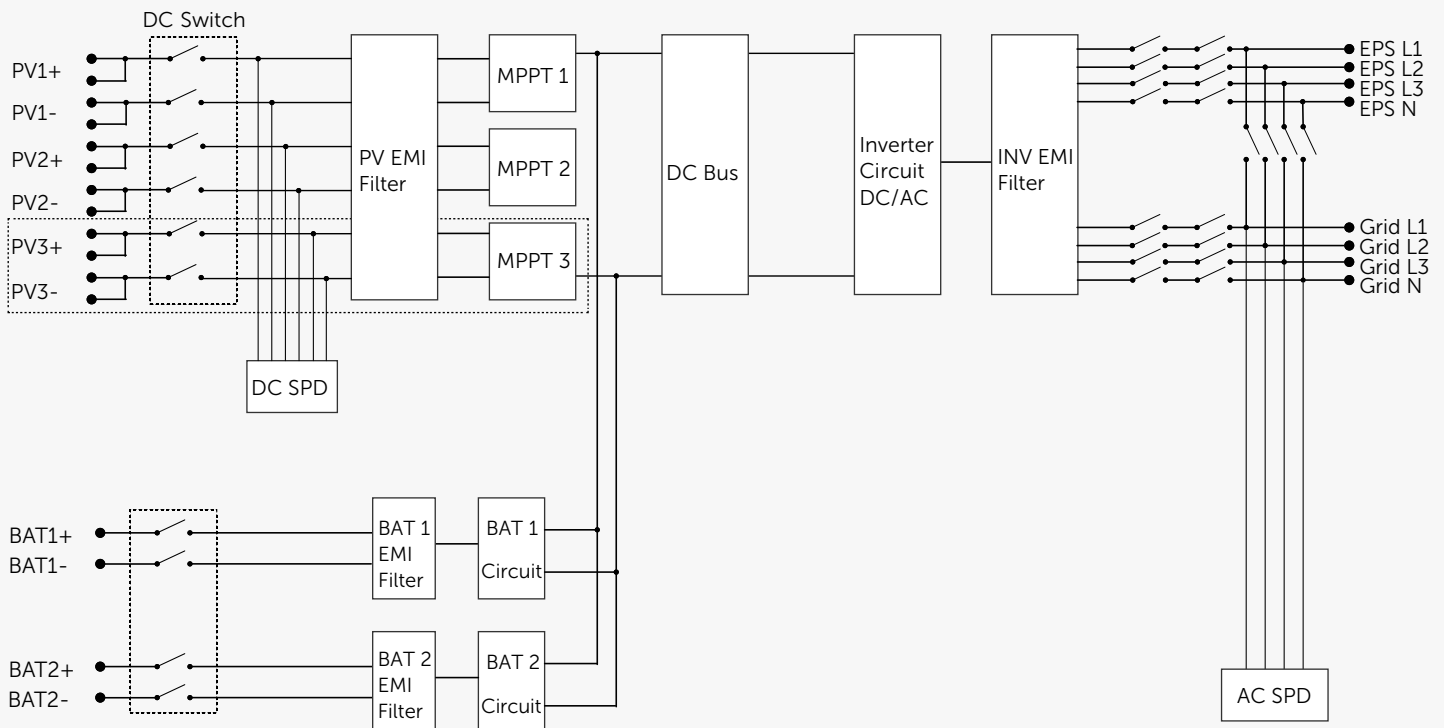

TYPICAL SCENARIO

PARTIAL SOLUTION

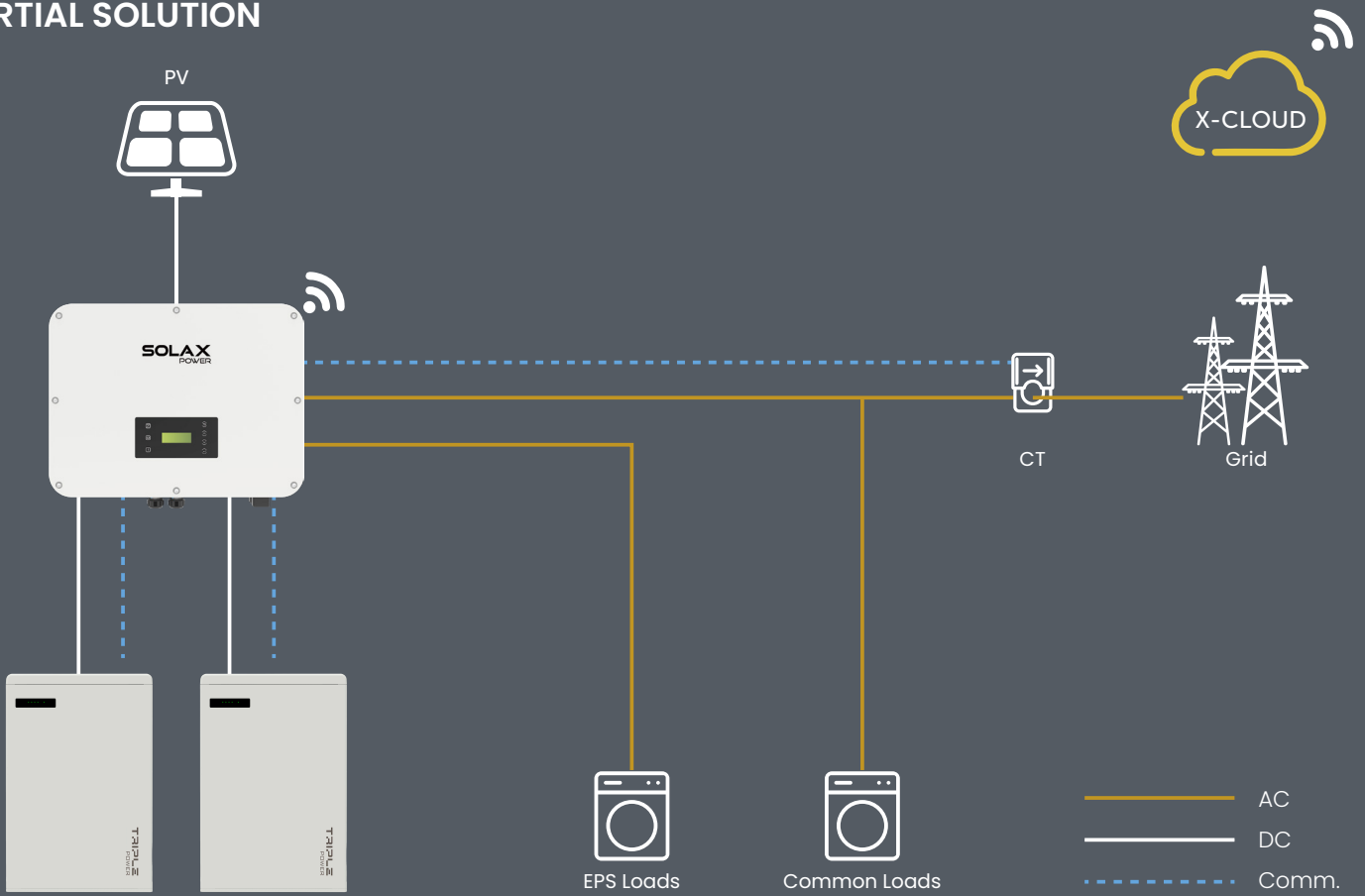

WHOLE HOME BACKUP SOLUTION

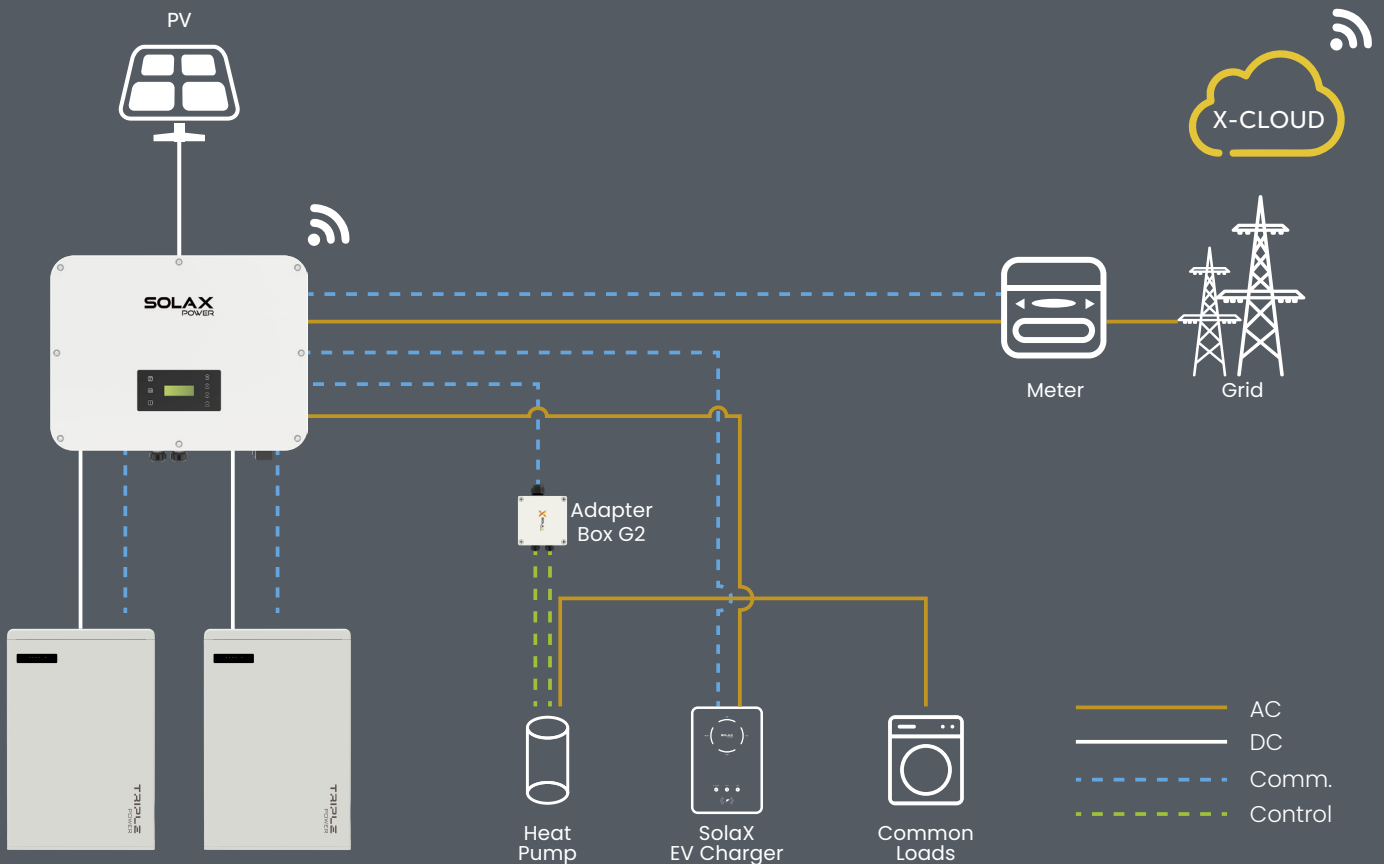

ZERO INJECTION SOLUTION

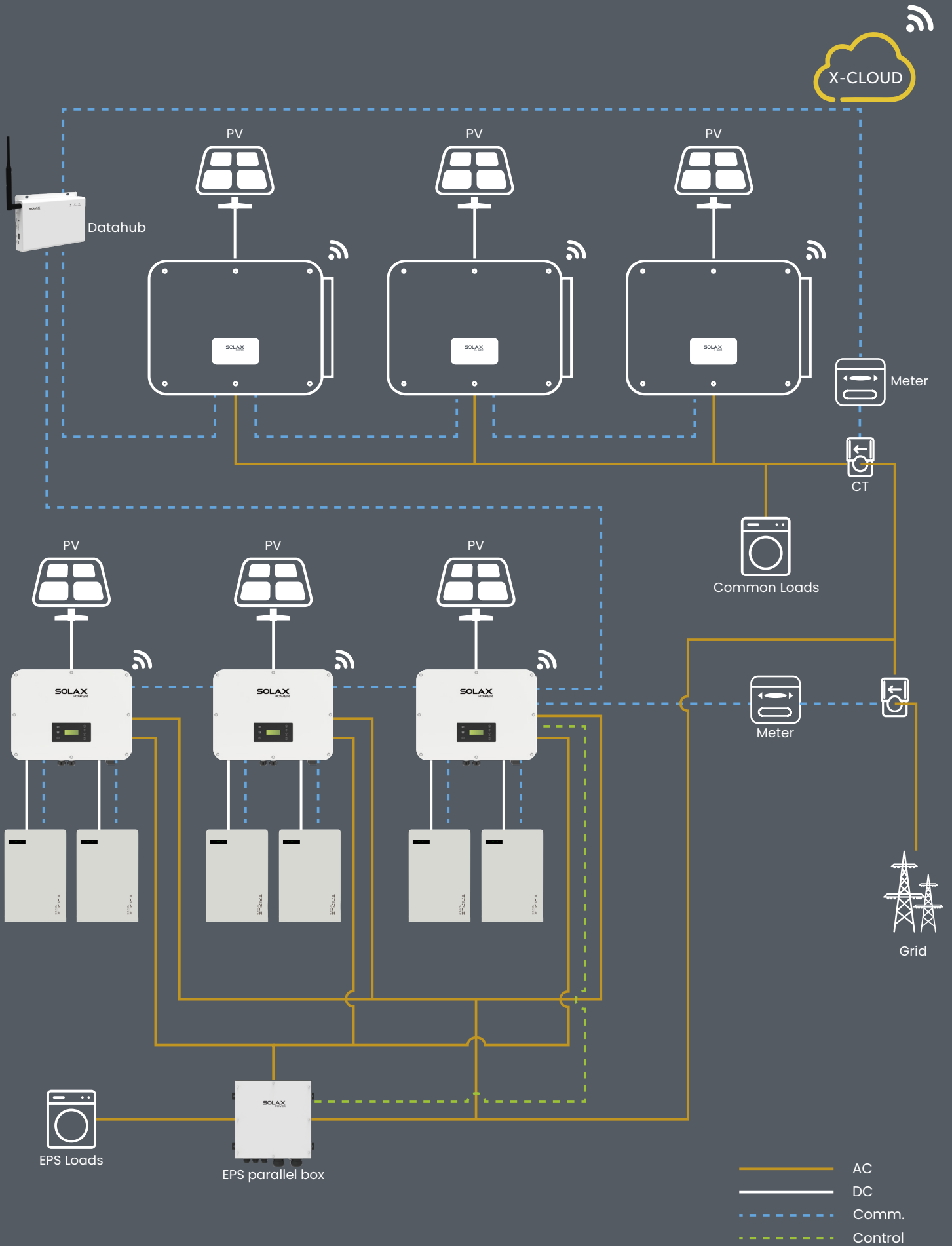

PARALLEL & GENERATOR INTEGRATED SOLUTION

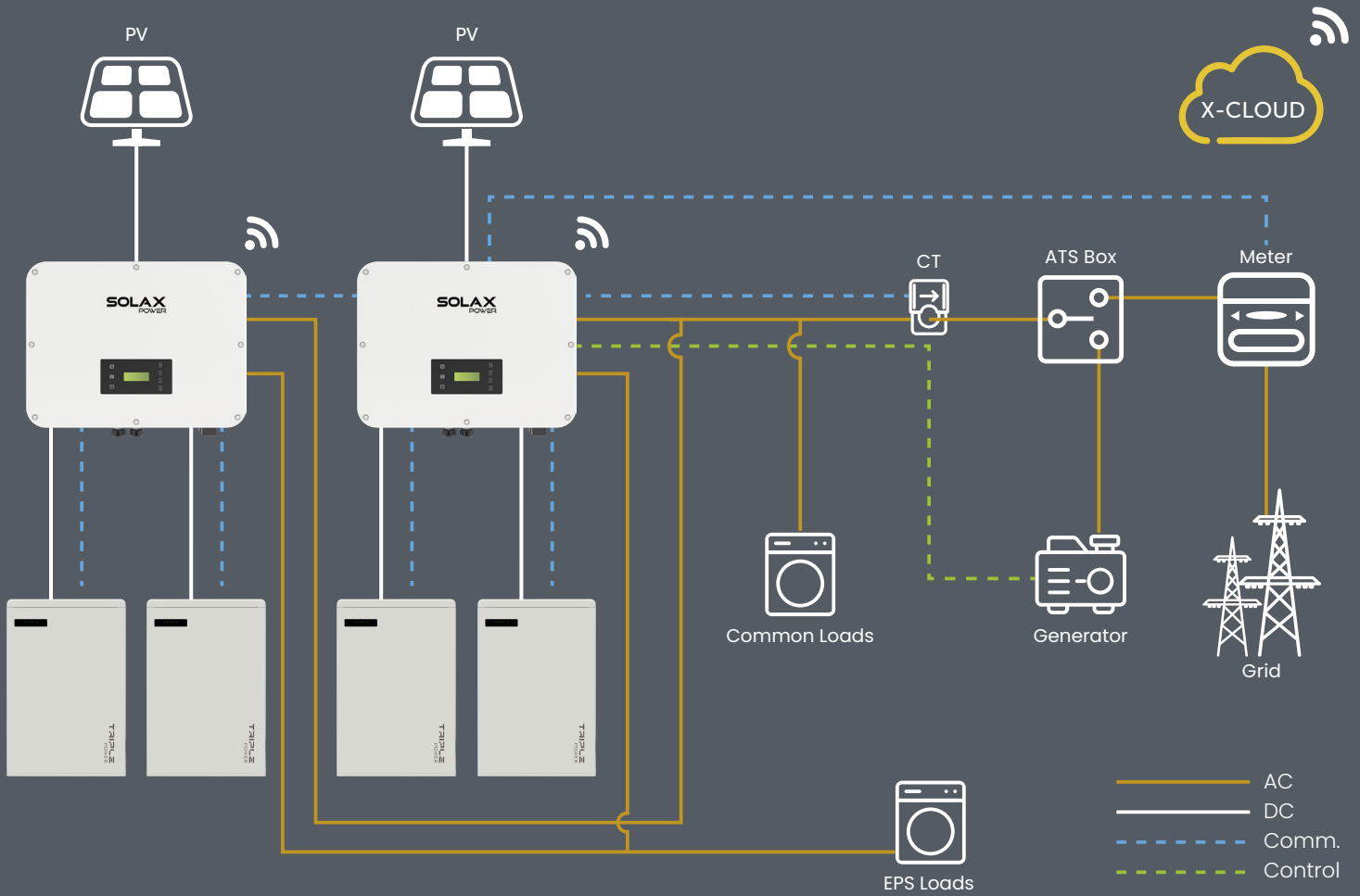

EFFICIENCY CURVE (EU)

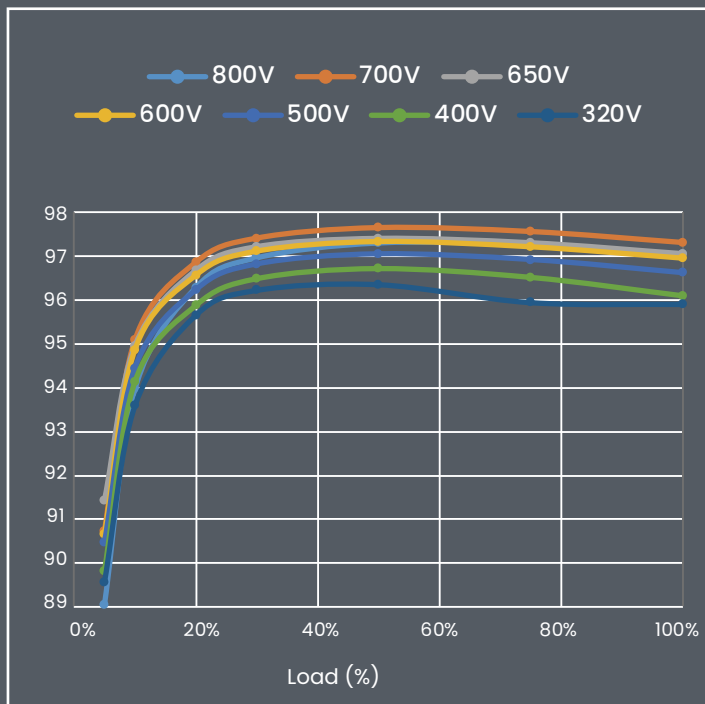

DERATING CURVE

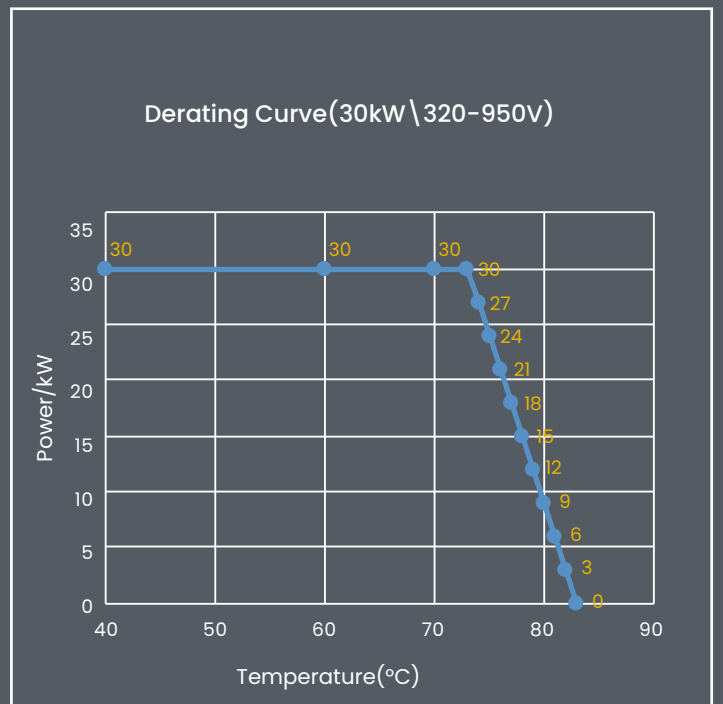



www.solaxpower.com