

Quick Installation Guide

X3-Matebox basic



1. Introduction

X3-Matebox basic is a critical part in one energy storage system, which integrates the DC breaker/AC breaker/switch unit/CT and so on, it can easily be installed compare to the traditional separate system, this unit can be used with Hybrid and Fit series inverters.

There are 2 wiring diagrams for your system connection reference, please follow your local policy to chose which one is suitable for your side.

Diagram A: N line and PE line separate wiring, D series inverters; (For most countries)

Diagram B: N line and PE line together, D series inverters; (Applicable to Australia)

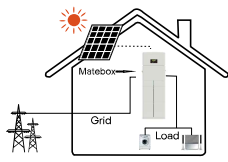
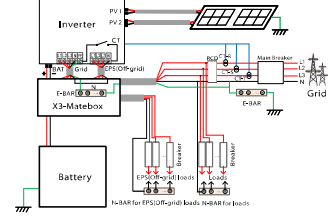
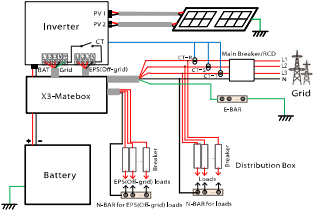

2. Overview

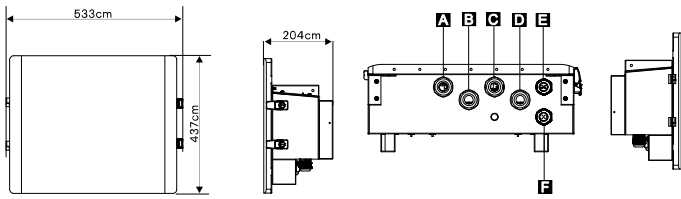

Object	Name	Description
A	Load	Load connection port
B	Grid	Grid connection port (to local grid)
C	Grid(INV)	Grid output port of the inverter
D	EPS(Off-grid) (INV)	EPS(Off-grid) output port of the inverter
E	BAT	Battery connection port (to battery BMS)
F	BAT(INV)	Battery connection port of the inverter

3. Preparation

3.1 Check Packing List

Check the accessories according to the following list and ensure that nothing in the package is damaged before installation.

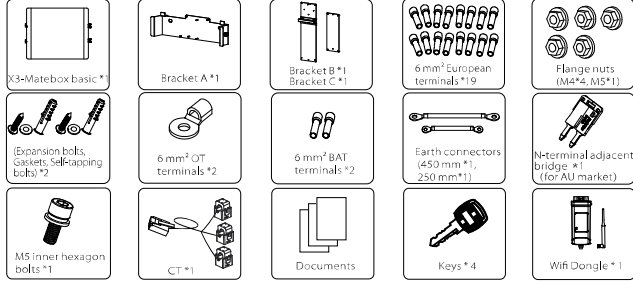

3.2 Tools

The following tools need to be prepared before installation:



4. Mounting

The installation of X3-Matebox basic needs three brackets. Bracket A is used to hang the X3-Matebox, Bracket B is connected to both inverter bracket and Bracket A to fix the bracket position of the inverter, and Bracket C is connected to both Bracket A and BAT bracket to fix the bracket position of T-BAT-SYS-HV-(3.0).

The bracket can be installed in two ways:

- 1) With T-BAT-SYS-HV-(3.0) battery, the installation method is as follows: ① ② ③ ④ ⑤
- 2) With other batteries, the installation method is as follows: ① ② ③

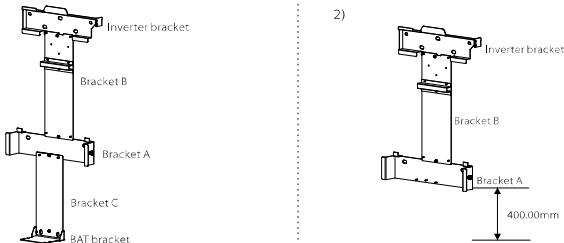

Note: When brackets are mounted, a spirit level is used to keep inverter bracket and Bracket A parallel to the ground. Bracket A should be installed at a distance of 400mm (at least) from the ground if other batteries are to be installed.

Step 1: Connect all brackets

Connect inverter bracket, Bracket B, Bracket A, Bracket C and BAT bracket all together with flange nuts.

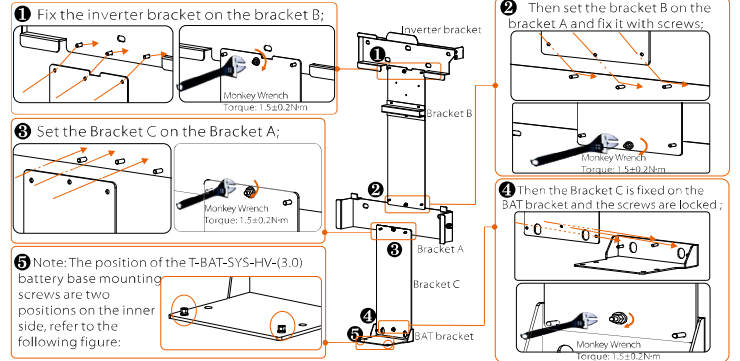

Step 2: Connect the BAT bracket and T-BAT-SYS-3.0 battery and push the whole structure to the wall

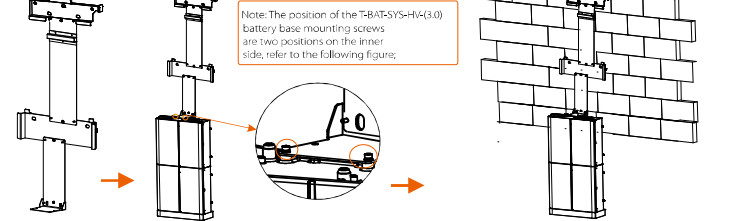

Step 3: Fix the position, drill holes and install the whole structure on the wall

a) With the position of the brackets as a template; in step 2, use a spirit level to mark the nine holes needed on the wall with a marker pen.



c) Insert expansion bolt into the nine hole, use rubber hammer to knock the expansion screw bolt into the wall.

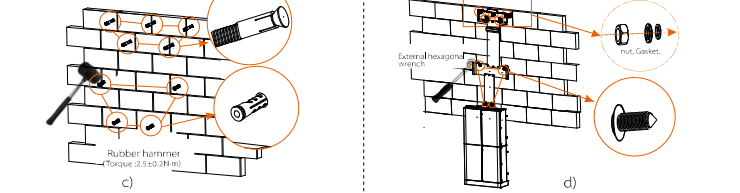

Step 4: Install the inverter

Make sure all brackets (bracket A, bracket B, bracket C, inverter bracket and BAT bracket) are well and firmly installed.

a) Before install the inverter, remove the "DONGLE" waterproof plug (for the installation of communication accessories); Insert wifi into DONGLE port and lock DONGLE port and lock the four screw on the wifi to fix its position.

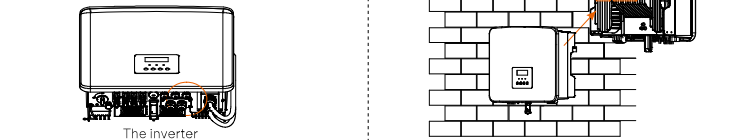

c) Use the inner hexagonal wrench to tighten the inner hexagonal screw on the right side of the inverter.

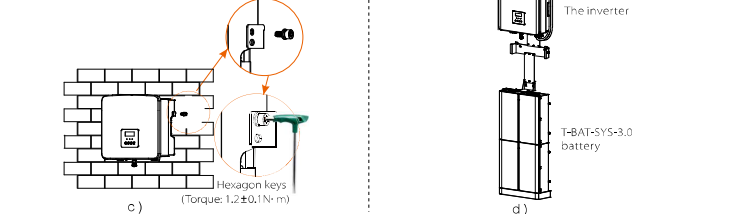

Step 5: Install X3-Matebox basic

a) Cut off all strips of the box except the strips of the back of the box before installing the box. Open the unlocked buckles of X3-Matebox basic, open the upper cover and remove the protective cover; (open the button by hand, open the cover and slide upwards.)

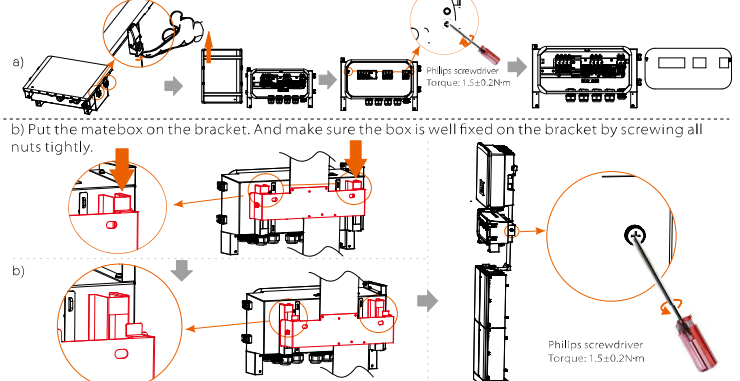

5. Monitor the antenna connections of accessories

There is an antenna in the box of monitoring accessories.

- Install the antenna on bracket A and tighten it by hand;
- Then connect the antenna cable to the end of the WiFi Dongle.

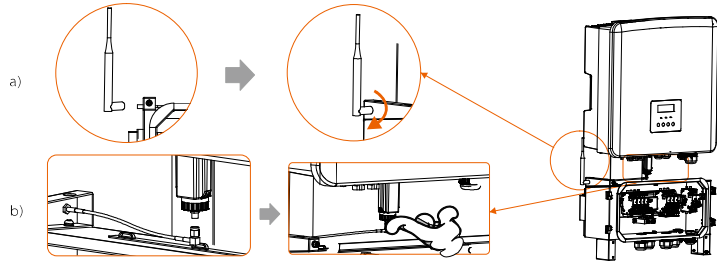

6. Wiring Connection

6.1 Inverter side connection

According to the BAT(INV)+/BAT(INV)- line symbol on X3-Matebox basic harness, the corresponding ports of BAT+/BAT- of the inverter are well inserted.

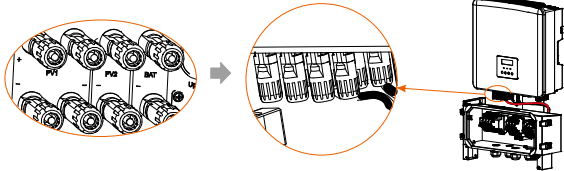

6.2 X3-Matebox side connection

- Lock the Grid (INV) PE wire with a hexagonal key;
- Insert the L1/L2/L3 EPS (Off-grid)(INV) into the R/S/T port of EPS (Off-grid) (INV) in X3-Matebox basic and the N EPS (Off-grid)(INV) directly into the hole and ensure that cables are well and tightly installed;
- Find the Grid (INV) (R/S/T) port in the X3-Matebox basic, connect the corresponding wire harness, and lock the screw with a screwdriver.
- Connect the Grid (INV) L1/L2/L3/N and EPS(Off-grid) (INV) L1/L2/L3/N/PE ports of the inverter to the X3-Matebox basic port. The connection method is as follows:

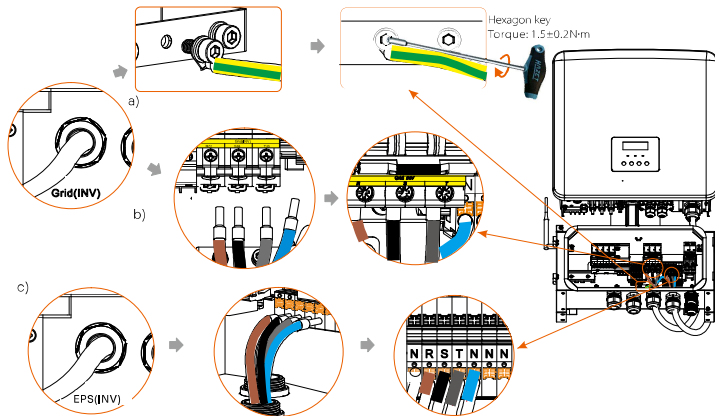

2) Grid (L1/L2/L3/N/PE) /Load (L1/L2/L3/N) side connection

- Prepare ordinary 6 mm² Grid (L1/L2/L3/N/PE) /6 mm² Load (L1/L2/L3/N) cable, remove 12 mm insulation layer from the end of the cable. And insert the European-style terminals respectively. The stripped terminals must be inserted into the European-style terminals and pressed down with the crimping pliers.

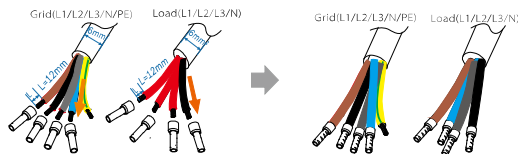

- Grid (PE) strip the grounding cable, remove the 13 mm insulation layer from the end of the wire. Insert the stripped cable into the R type terminal, and then clamp it.

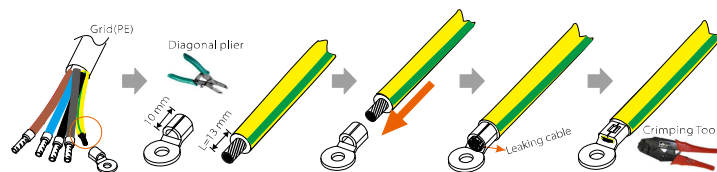

- Pass the Load line through the Load port of the X3-Matebox basic, then find the Load (R/S/T/N) ports in the X3-Matebox basic, insert each line accordingly, and use the screwdriver to lock the screws.

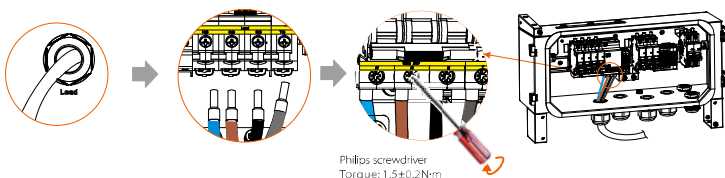

- Pass the Grid line through the Grid port of the X3-Matebox basic, and then find Grid (N/R/S/T) port inside the X3-Matebox basic. Force the cable harness directly into the hole to jam, gently twist not to loosen. Grid (PE) is locked with a Hexagonal key.

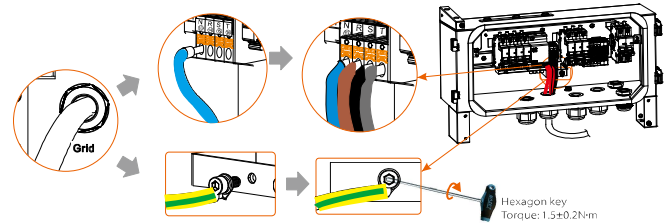

- Pass the battery cable through the BAT port of the X3-Matebox basic, find the BAT+ and BAT- ports in the X3-Matebox basic, insert each cable accordingly, and use the screwdriver to lock the screws.

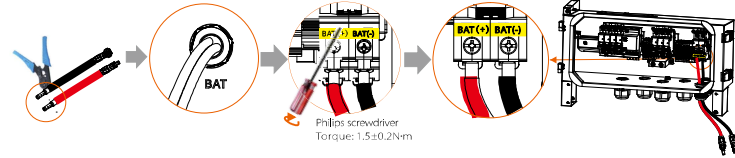

6.3 Ground cable connections

There are three parts that need to be grounded, one is between the inverter and X3-Matebox basic, the connection between the X3-Matebox basic and the battery and the connection of the upper cover and the X3-Matebox basic.

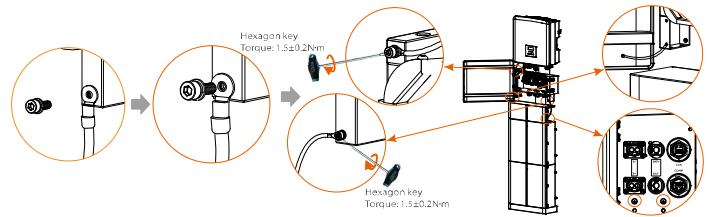

6.4 Battery communication cable connection

- When the distance between the X3-Matebox basic and the battery is < 1m, you can use the BMS communication cable in the accessory bag.
 - When the distance between the X3-Matebox basic and the battery is > 1 m, you need to prepare the regular network cable and find the RJ45 terminal of the accessory package to make the cable.
- The BMS port connection between the inverter and the battery (for the specific connection method, please refer to the inverter and battery quick installation guide)

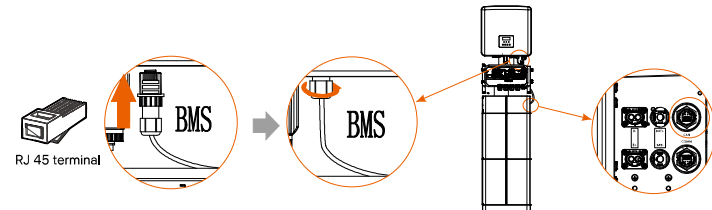

6.5 N lines short circuit (applicable in Australia)

According to local regulations, the continuity of the neutral cable of EPS load and that of the grid is not interrupted when the inverter disconnects from the grid. (for wiring Australia and New Zealand regulation AS/NZs_3000:2012)

- Firstly, find N-terminal adjacent Bridge in the accessory package; Forcibly insert N-terminal adjacent bridge into the N-terminal hole and jam it. Gently twist to well connect it.

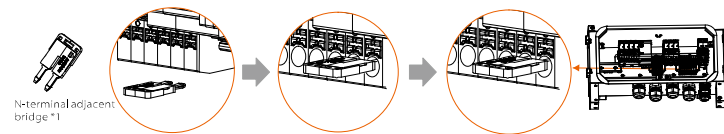

- Finally, use a Philips screwdriver to install the baffle back, install the upper cover and lock the buckle with a key.

