

Quick Installation Guide X1-Matebox



1. Introduction

X1-Matebox is a critical part for SolaX all in one energy storage system, which integrates the DC breaker/AC breaker/switch unit/CT and so on, it can easily be installed compare to the traditional separate system, this unit can be used with SolaX X1-Hybrid G4 and X1-Fit G4 series inverters.

There are 2 wiring diagrams for your system connection reference, please follow your local policy to chose which one is suitable for your side.

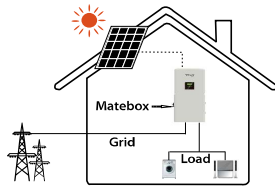
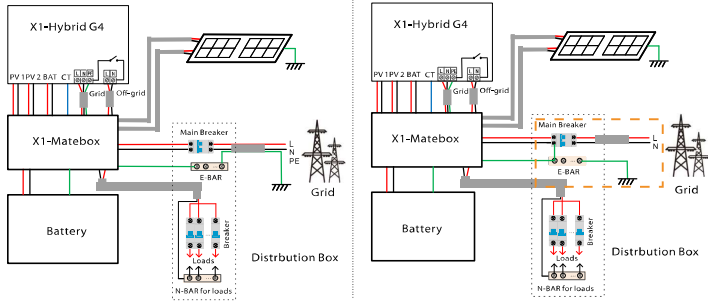
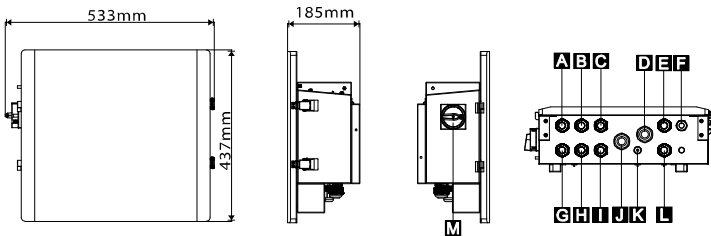

Diagram A: Neutral line and PE line are separated from each other, all loads connect to the Off-grid port;

Diagram B: Neutral line and PE line are combined together, all loads connect to the Off-grid port;



2. Overview



Object	Name	Description
A	PV	PV connection port (PV array)
B	Off-grid1	Off-grid1 output port of the inverter
C	Grid1	Grid1 output port of the inverter
D	Load	Load connection port
E	BAT	Battery connection port (to battery pack)
F	CAN	Reserved
G	PV (INV)	PV connection port of the inverter
H	Off-grid 2	Reserved
I	Grid 2	Reserved
J	Grid	Grid connection port (to local grid)
K	CT	CT connection port of the inverter
L	BAT(INV)	Battery connection port of the inverter
M	DC Switch	DC switch

3. Preparation

3.1 Check Packing List

Open the package and check the materials and accessories according the following list.

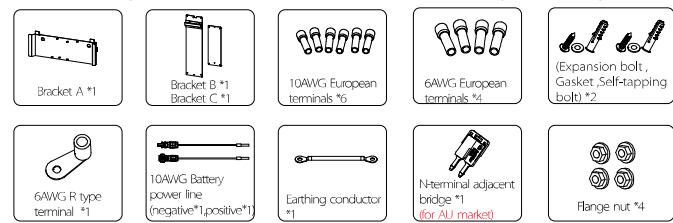

3.2 Tools

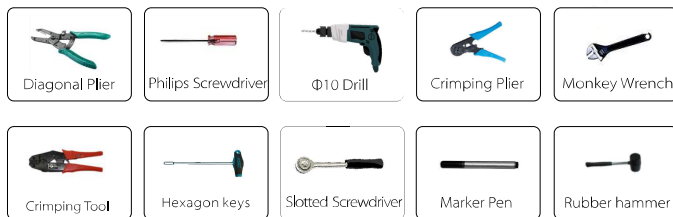

4. Mounting

The bracket of the X1-Matebox is composed of three parts. Bracket A is used to install the X1-Matebox, Bracket B is used to fix the bracket position of the inverter, and Bracket C is used to fix the bracket position of T-BAT-SYS-HV-(3.0).

The bracket can be installed in two ways:
 1) With T-BAT-SYS-HV-(3.0) battery, the installation method is as follows: (1 2 3 4 5)
 2) With other batteries, the installation method is as follows: (1 2 3)

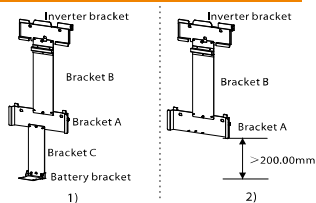

Step 1: Screw the wall bracket on the wall

First splice the inverter bracket, bracket A, bracket B, and battery bracket according to the steps, and then fasten them to the wall.

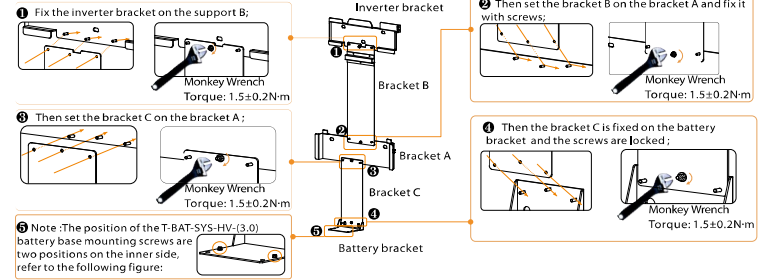

Step 2: Then install the T-BAT-SYS-3.0 battery bracket ;(Please refer to T-BAT-SYS-3.0 battery quick installation guide)

Step 3: Mounting bracket A

The mounting method of the X1-Matebox bracket is as follows:

- Use the bracket as a template to mark the two holes on the wall with a marker pen.
- Drill holes at marked spots with depth of 80mm.

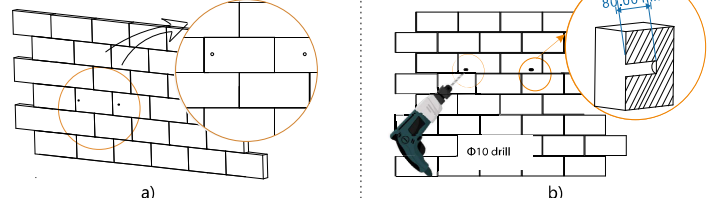

- Insert expansion bolt into the hole, use rubber hammer to knock the expansion screw bolt into the wall.
- The bracket is aligned with the screw uses the inner hexagonal wrench to screw the tapping screw until the expansion bolt "bang" is heard.

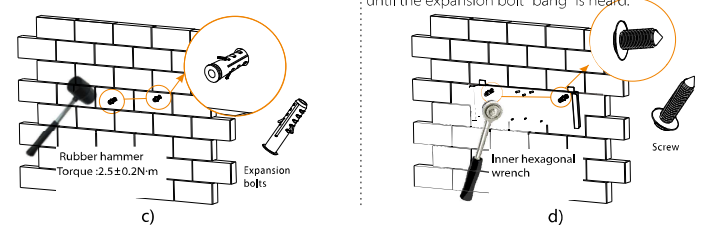

Step 4: Finally install the X1-Hybrid G4 inverter bracket (please refer to the X1-Hybrid G4 inverter quick installation guide).

Step 5. Install the X1-Matebox on the wall and lock the screws.

Use a level first to ensure that the brackets (battery bracket, bracket A, bracket B, bracket C, inverter bracket) in the system are firmly installed and level. Then follow the steps below to hang X1-Matebox.

- Before install the inverter, connect the ground wire firstly, and remove the "DONGLE" waterproof cover (for the installation of communication accessories); Please refer to the pocket dongle (WiFi) quick installation guide
- Firstly install the battery and inverter on the wall, and then install the X1-Matebox on the wall;

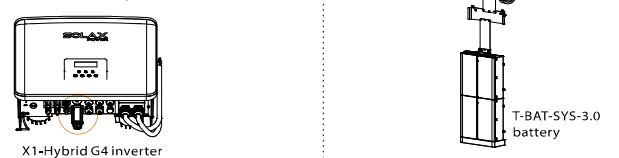

- Open the X1-Matebox buckle, remove the cover, and take out the front protective cover.

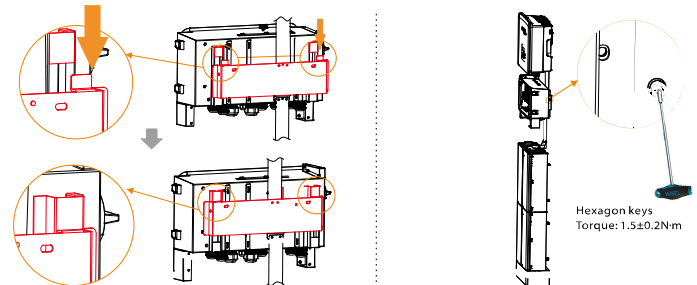

5. Monitor the antenna connections of accessories

There is an antenna in the box of monitoring accessories.

- First open the upper cover of X1-Matebox and remove the baffle; (open the button by hand, open the cover and slide upwards, and remove the isolation plate)

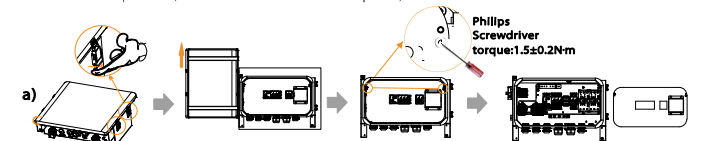

- Install the antenna on bracket A and tighten it by hand;
- Then connect the antenna cable to the end of the pocket WiFi.

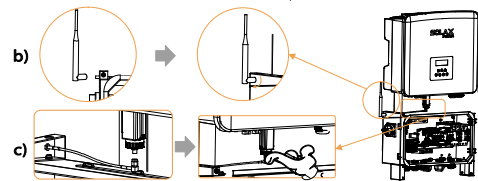

6. Wiring Connection

6.1 Inverter side connection

- a) According to the PV 1(INV)/PV1(INV)/PV2(INV)/PV2(INV)/BAT(INV)/BAT(INV)- line symbol on X1-Matebox, Correspond to the PV 1 + / PV1 - / PV2 + / PV2 - / BAT + / BAT - ports of the inverter.
- b) Connect the CT cable of the X1-Matebox to the CT port of the inverter, and tighten the waterproof plug.

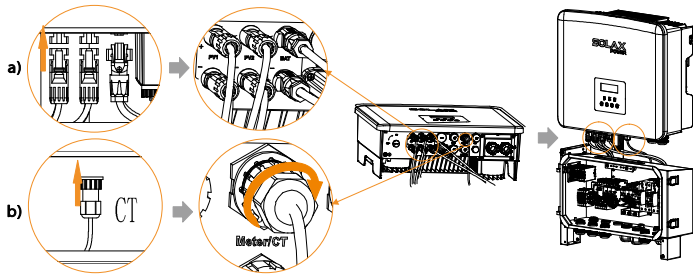

6.2 X1-Matebox side connection

- 1) Connect the Grid1 L/N and Off-grid1 L/N/PE lines between the inverter and X1-Matebox. The connection method is as follows:
- a) First, insert Grid1 L/N and Off-grid1 L/N into the X1-Matebox port firmly, and then gently pull to check if they are connected properly;
- b) Connect to the Grid (PE), use a hexagonal keys to tighten the screws;

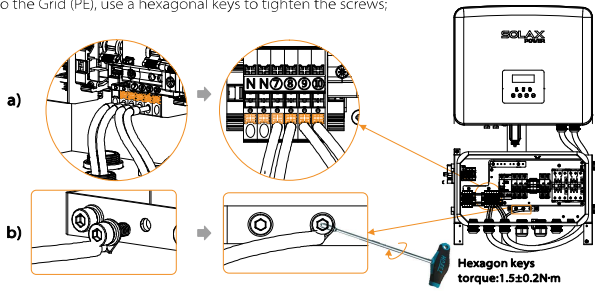

2) PV(PV1+/PV1-/PV2+/PV2-) /Grid(L/N/PE) /Load(L/N) side connection

- a) PV(PV1+/PV1-/PV2+/PV2-) /Grid(L/N/PE) /Load(L/N) wire, remove the 12mm insulation layer at the end of the wire. Insert The European-style terminals respectively. The stripped terminals must be inserted into the European-style terminals and finally pressed down with the crimping pliers.

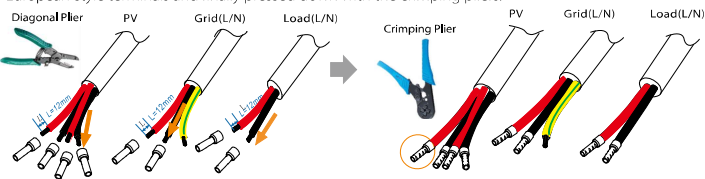

- b) Grid(PE) strip the grounding cable insulation(lenhth"12"), insert the stripped cable into the R type terminal, and then clamp it.

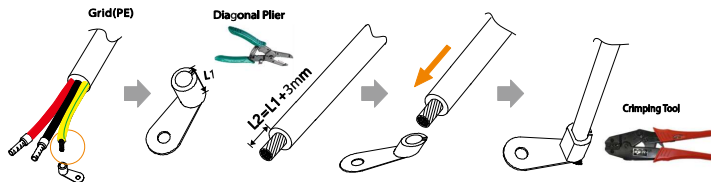

- 3) Pass the PV line through the PV port of The X1-MateBox, and then find PV1+/PV1-/PV2+/PV2+ port inside the X1-Matebox. Force the wire harness directly into the hole to jam, gently twist not to loosen.

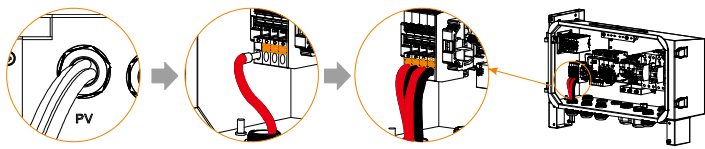

- 4) Pass the Grid/Load line through the Grid/Load port of the X1-Matebox, then find the Grid (L/N) and Load (L/N) ports in the X1-Matebox, insert each line accordingly, and use the screwdriver to lock the screws.

Grid (PE) is secured with an inner hexagonal keys.

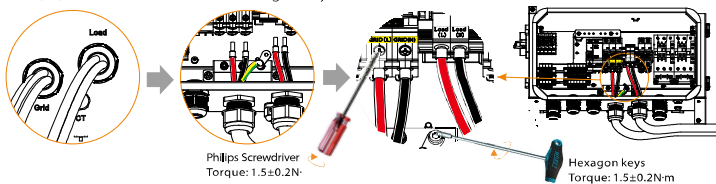

- 5) Pass the battery power wire through the BAT port of The X1-Matebox, then find the BAT+ and BAT- ports in the X1-Matebox, insert each wire accordingly, and use the philips screwdriver to lock the screws.

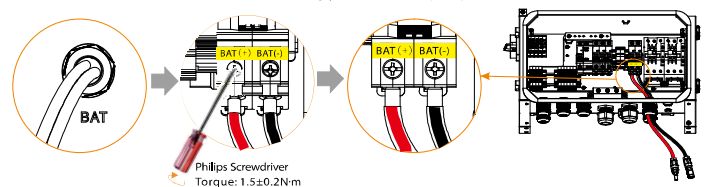

6.3 Ground wire connections

There are two areas that need to be grounded, one between the inverter and X1-Matebox and the other between the X1-Matebox and the battery.

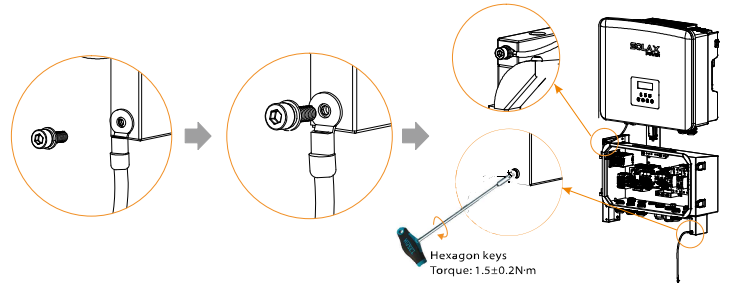

6.4 Battery's communication wire connection

- When the distance between the X1-Matebox and the battery is < 1 m, you can use the BMS communication line in the accessory bag.

- When the distance between the X1-Matebox and the battery is > 1 m, you need to prepare the regular network cable and find the RJ45 terminal of the accessory package to make the cable.

The BMS port connection between the inverter and the battery (for the specific connection method, please refer to the inverter and battery quick installation guide).

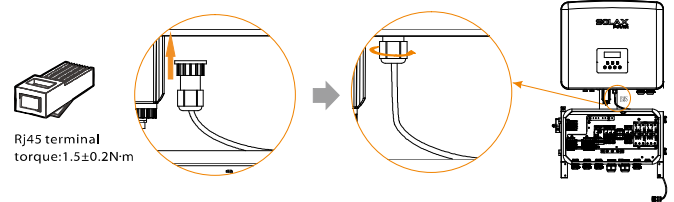

6.5 N lines short circuit (applicable in Australia)

- If the user requires wiring rules for neutral wires the standby power supply cannot be isolated or switched (for wiring Australia and New Zealand regulations AS/ NZs_3000:2012).

-First, find N-terminal adjacent Bridge in the accessory package,

-Forcibly insert n-terminal adjacent bridge into the n-terminal hole and jam it.Gently twist and do not relax.

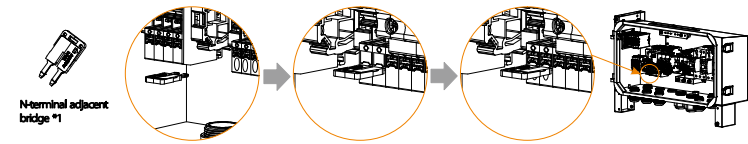

- 6.6 Finally, use a philips screwdriver to install the baffle back, install the upper cover, and then lock the buckle by hand.

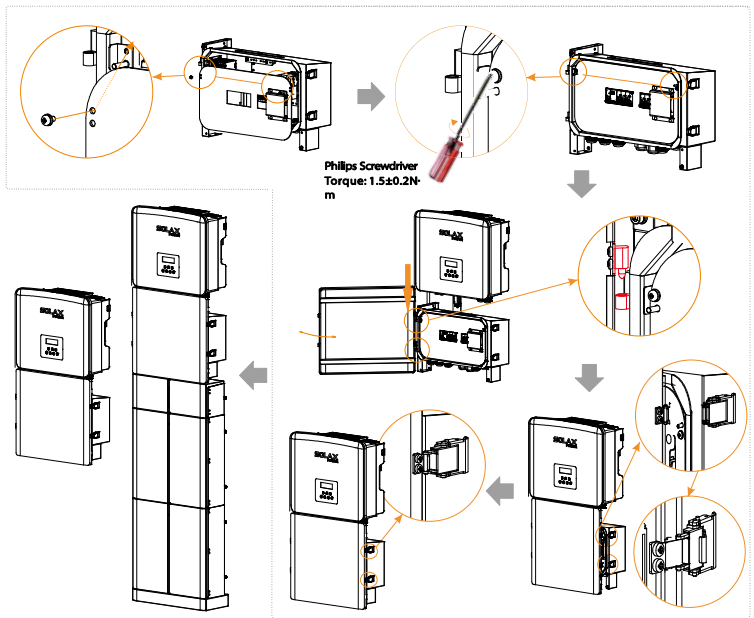

7. Technical Parameters

DC Input/Output	
Max. Input Voltage	600V
Max. Short Current	16A/16A
Battery Voltage Range	80-480V
Max. Charge/Discharge Current	30A/30A
GRID Input/Output	
Rated Grid Voltage ,Frequency	220/230Vac ,60/60Hz
Max. Short Current	60A
LOAD Input/Output	
Rated Grid Voltage ,Frequency	220/230Vac ,60/60Hz
Max. Short Current	60A
Installation Specification	
Dimension (L*W*H)	437mm*533mm*185mm
Weight	10kg
Operating Temperature	-35°C~+60°C
Installation	Wall Mounted